

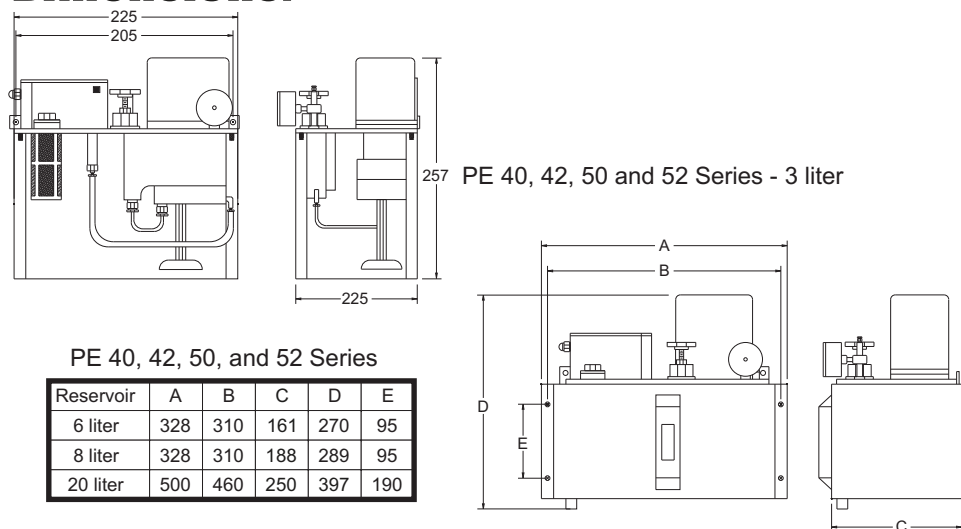

## Continuous Pumps PE-40, PE-42, PE-50, PE-52 Series

# Read Instructions Before Installing

## Dimensions: Dimensions in mm



## Specifications:

Reservoir Capacity	3 liter plastic 6, 8 and 20 liter steel
Motor Voltage	110v 50/60 standard 220v 50/60 optional
Pump Type	Gear pump
Maximum Pressure	140 psi
Output Volume	250 cc/min
Output Connection	5/16-24 (f)
Low Level Switch	Voltage: 12 VDC Output Capacity: 0.5 Amps



## Continuous Pumps PE-40, PE-42, PE-50, PE-52 Series

# Read Instructions Before Installing

## To Install:

- Obtain all available information from the system designer. This may include bill of materials, lubrication point locations, etc.
- Continuous pumps deliver oil to the system on a continuous basis or whenever electrical current is supplied to the motor.
- Mount the reservoir in the desired location. It should be:
  - Visible to the operator.
  - Easy to re-fill and service.
- Mounting hole dimensions and clearances are shown on the inside of this instruction sheet.
- Electrical Connections - consult a qualified electrician.
  - Always follow local electrical codes, safety regulations and procedures when installing an electrical system.
  - Wire the pump to the switched side of the machine disconnect so the two are energize simultaneously.
  - Wire per the schematic on the inside of this instruction sheet.
- Units with a low level float switch, when the switch is activated, it will shut down the motor to avoid damage to the pump and activate the alarm.
- The pressure setting determines the amount of lubrication delivered and is a result of the designers' calculations. It is advisable to install a pressure gauge at the furthest point in the system. The first gauge indicates that the pump is operating the second gauge indicates that there is pressure at the furthest point in the system.
- Pressure Adjustment
  - The black knob located on the front of the unit is used to adjust the pressure. To set pressure release black locking nut.
  - Turn black knob to set desired pressure. Turn knob clockwise to increase pressure and counter-clockwise to decrease pressure. Once desired pressure is obtained, secure the nut.
  - PE-40 Series only. If your system is designed for the pump to turn off and on in a cyclic manner you may press and hold the green button located on the front of the unit for the desired time to obtain instant lubrication.
- General installation practice is to mount the control units at each lubrication point and interconnect them with tubing. Always point arrow on control unit in direction of flow. Follow your system schematic. When connecting pipe threads apply a small amount of thread sealant to the external thread. If at all possible, the most distant lubrication point should be piped in an upward position from pump.
- Piping is done with metal or plastic tubing. Take care to prevent dirt or contamination from entering into the piping. You may choose to leave a final fitting (near the control unit) slightly loose to facilitate the initial bleeding of air and checking of oil delivery to each point. Failure to observe oil at a point requires tracing the system back towards the pump in search of a kink in a line, a loose fitting, or other problems.
- Always use clean oil poured from a clean container. Do not mix oil types or change viscosity without consulting your machine manufacturer.
- Clean the reservoir and filter elements periodically as dictated by the oil cleanliness. If in doubt, check for cleanliness at 3 months, and then 6 months. Determine service frequency based on what is found.
- If contamination enters the system, disconnect lines and flush them out. Empty reservoir, clean filter elements and re-fill the system with clean lubricant.

**NOTE:** Units with return line tank option, it is recommended to have an in-line filter on the return line.



# Read Instructions Before Installing

## Wiring PE-40 and PE-42 Series:

1. Remove the cover over the connectors (fig. 1).

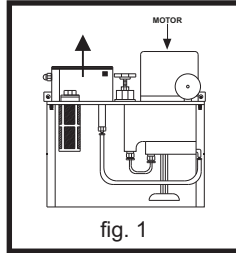

2. Wire per schematic option below.

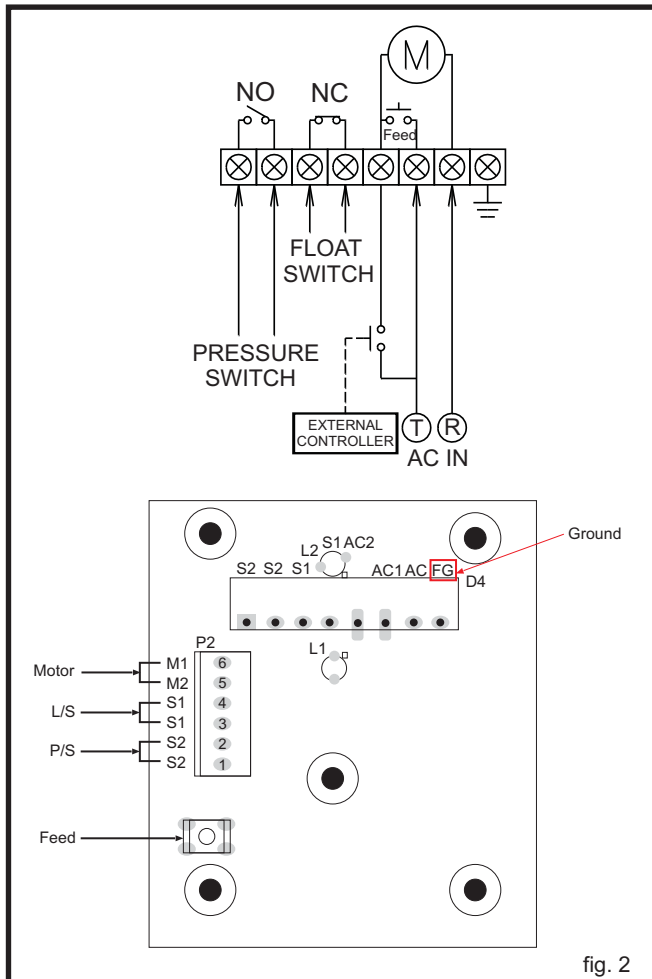

# Read Instructions Before Installing

## Wiring PE-50 and PE-52 Series:

1. Remove the cover over the connectors (fig. 1).

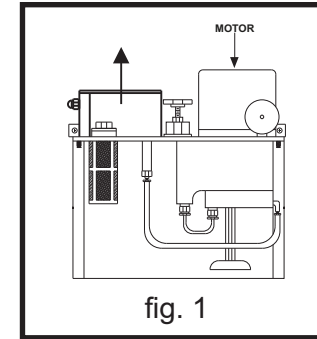

2. Wiring per schematic will allow the low level switch to shut down the pump when activated(fig. 2).

